

Endoscopy Video Cart classic-cart



The perfect mobile base
for modern video endoscopy
systems.



PENTAX



The PENTAX classic-cart. A new generation of endoscopy video trolley. A high-quality, innovatively designed cart providing the perfect mobile base for daily use in the doctors office/clinic.

Outstanding performance characteristics



Quality and Functionality

- Sturdy, highly resilient chassis.
- Roller-guided drawer with self-closing action.
- Weight capacity of each shelf is up to 50 kg.
- Fully extendable pull out keyboard rack.
- Rotatable TFT monitor holder (shelf may also accommodate a CRT monitor).
- Lockable rear doors.
- Maneuverable double swivel castors Ø 125 mm, both front castors can be locked into place.
- All metal elements with impact-resistant powder coating.

Included Accessories

- Standard railing, height-adjustable double-holder for endoscopes, holder for accommodating up to three endoscope connector plugs, cable hanging bracket.

Electrical Components

- Electrical system: insulation transformer (1600 VA), central on/off switch, 8-outlet strip with circuit breaker for each outlet and one POAG plug per module slot.
- Electrical safety complies with standards and guidelines DIN EN 60742 (VDE 0551) and DIN EN 60601-1 (VDE 0750).

Technical Details

classic-cart

Weight (kg)

70

Dimensions (H x W x D) mm

1277 x 614 x 625

Cart load capacity (max. kg)

150

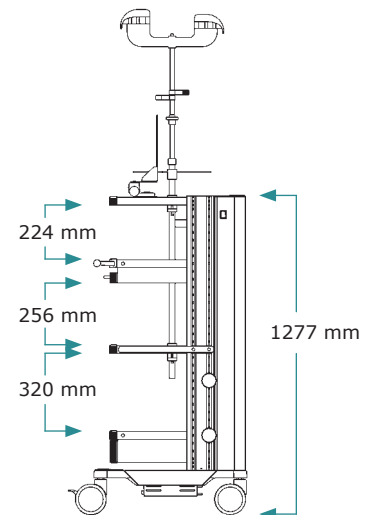
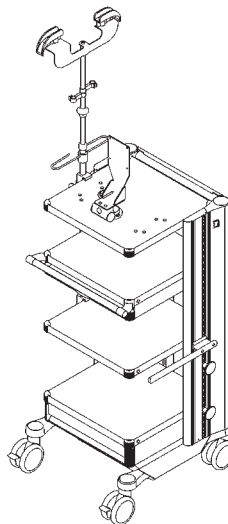

PENTAX Europe GmbH
LIFE CARE
Julius-Vosseler-Straße 104
22527 Hamburg
Germany
Tel.: +49 40 / 5 61 92 - 0
Fax: +49 40 / 5 60 42 13
E-mail: medical@pentax.de

PENTAX U.K. Limited
LIFE CARE
Pentax House
Heron Drive, Langley
Slough SL3 8PN
United Kingdom
Tel.: +44 17 53 / 79 27 23
Fax: +44 17 53 / 79 27 94
E-mail: lifecare.info@pentax.co.uk

PENTAX France S.A.S.
LIFE CARE
112 quai de Bezons
P. B. 204
95106 Argenteuil
France
Tel.: +33 1 / 30 25 75 75
Fax: +33 1 / 30 25 75 76
E-mail: medical@pentax.fr

PENTAX Nederland B.V.
LIFE CARE
Lage Mosten 35
4822 NK Breda
Netherlands
Tel.: +31 76 / 5 31 30 31
Fax: +31 76 / 5 31 30 00
E-Mail: lifecare@pentax.nl

PENTAX Italia S.r.l.
LIFE CARE
Via Dione Cassio, 15
20138 Milano
Italy
Tel.: +039 / 02 50 99 58 1
Fax: +039 / 02 50 99 58 60
E-mail: marketing.lifecare@pentaxitalia.it

HOYA Corporation
PENTAX Tokyo office
2-36-9, Maeno-cho
Itabashi-Ku
174-8639 Tokyo
Japan
Tel.: +81 33 / 9 60 51 55
Fax: +81 35 / 3 92 67 24

www.pentaxeuropa.com



PENTAX Corporation · ISO 9001/EN ISO 13485 certified

Your PENTAX sales representative:

PENTAX